

## 2.4 Interim frame

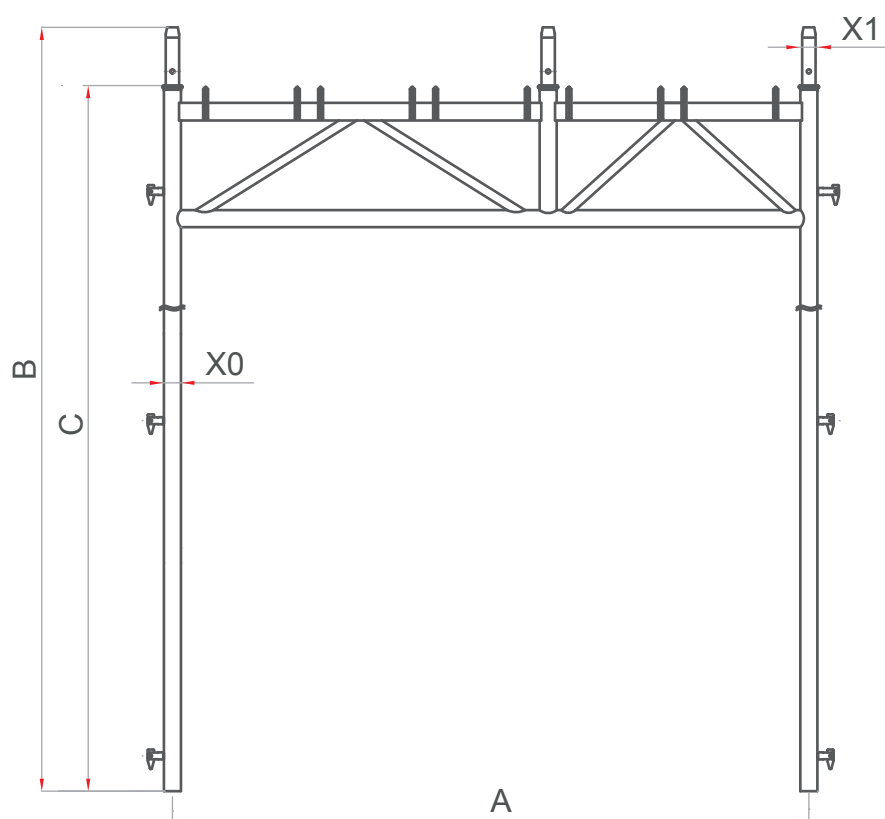

### Technical table

<b>A</b>	1804	<b>B</b>	2565	<b>C</b>	2400
<b>X0</b>	Ø48,3x2,7	<b>X1</b>	Ø38x2,7		
<b>Weight: 36 kg</b>					

